

COMPARTMENT DIMENSIONS					
COMPT.	DOOR OPENING	INTERIOR	DIVIDE HEIGHT	DEPTH	DEPTH
L1	58\"W x 18\"H	61.5\"W x 28.5\"H	13\"	13\"	13\"
L2	58\"W x 18\"H	63.5\"W x 28.5\"H	—	13\"	13\"
L3	51\"W x 47\"H	62\"W x 60.5\"H	37\"	14\"	26\"
L4	10\"W x 33\"H	12.5\"W x 39.5\"H	—	21\"	21\"
R1	58\"W x 18\"H	61.5\"W x 28.5\"H	—	13\"	13\"
R2	58\"W x 18\"H	63.5\"W x 28.5\"H	—	13\"	13\"
R3	51\"W x 47\"H	62\"W x 60.5\"H	37\"	14\"	26\"
R4	31\"W x 30\"H	36.5\"W x 39.5\"H	31\"	10\"	22\"
PR1	23\"W x 30\"H	32.5\"W x 39\"H	—	20\"	20\"

- SHOP INSTRUCTIONS**
- COMPARTMENT FINISH: LINE-X GRAY
 - SHELVES/TRAYS FINISH: ABRADED
 - INNOVATIVE CONTROLS LIFT DRAINS

GROUND LADDERS & PIKE POLES			
ITEM	DESCRIPTION	MODEL #	QTY
A	35' 2 SEC EXTENSION	PEL-35	1
B	24' 2 SEC EXTENSION	PEL-24	1
C	20' ROOF	DRL-20	1
D	16' ROOF	DRL-16	1
E	14' FRESNO ATTIC	AEL-14	1
F	10' FOLDING ATTIC	FL-10	1
G	4' D-HANDLE PIKE POLE	NHF-4 W/D	2
H	6' PIKE POLE	NHF-6	2
I	8' PIKE POLE	NHF-8	2
J	12' PIKE POLE	NHF-12	2
K	14' ROOF	PRL-14	1
L	6' PIKE POLE	FP6	1

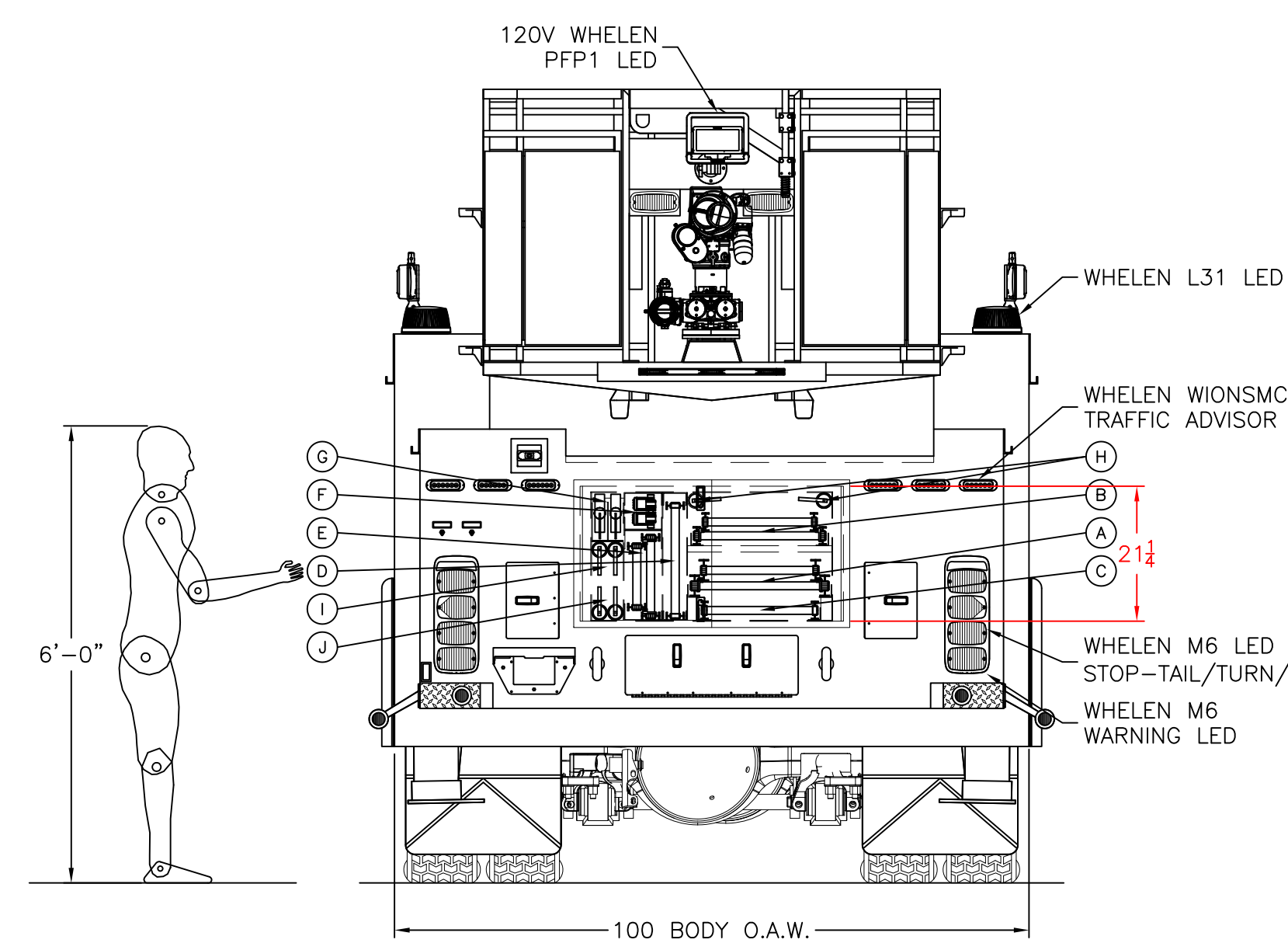
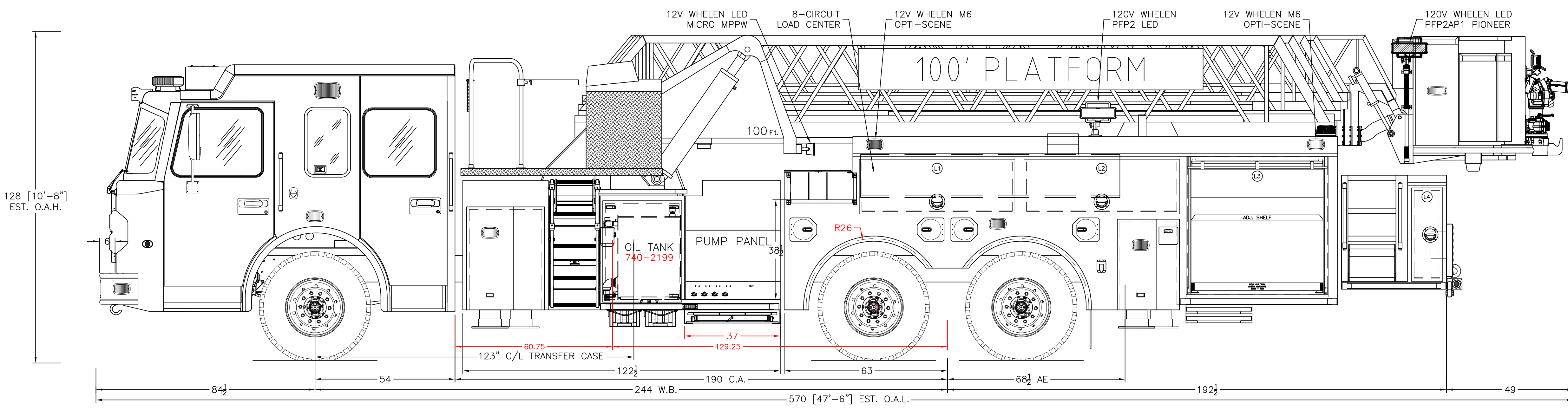

NOTE:
 THIS DRAWING IS THE PROPERTY OF SPARTAN MOTORS USA AND IS TO BE USED ONLY IN REFERENCE TO THE WORK PROPOSED OR CONTRACTED BY SPARTAN MOTORS USA ANY REPRODUCTION IN PART OR IN WHOLE WITHOUT THE WRITTEN PERMISSION OF SPARTAN MOTORS USA IS STRICTLY PROHIBITED.
 DIMENSIONS SHOWN ARE APPROXIMATE AND ARE SUBJECT TO CHANGE AS MAY BE FOUND NECESSARY DURING CONSTRUCTION. THIS DRAWING MUST BE PLOTTED TO THE PAPER SIZE LISTED IN THE TITLE BLOCK FOR THE LISTED SCALE TO BE VALID.
 THIS DRAWING IS FOR REFERENCE PURPOSES ONLY. SOME ITEMS MAY OR MAY NOT APPEAR ON THE DRAWING THAT MAY OR MAY NOT BE INCLUDED IN THE SPECIFICATIONS. THE SPECIFICATIONS SHALL BE THE FINAL AUTHORITY TO DETERMINE WHAT IS SUPPLIED ON THE APPARATUS.

REVISION HISTORY			
REV	INT	DATE	DESCRIPTION
01	KS	4/29/19	PRE CONSTRUCTION MEETING

**SHOP PRINT
 PRE-CONSTRUCTION**

CHASSIS: SPARTAN GLADIATOR MFD 10\" RAISED ROOF
 ENGINE: CUMMINS X15 600HP WITH ALLISON 4000 EVS
 PUMP: WATEROUS CSUD 2000 GPM
 WATER TANK: 300 U.S. GAL
 FOAM CELL: N/A
 BODY MATERIAL: 1/8\" ALUMINUM
 HOSE BED: 31 CUBIC FEET
 GENERATOR: HARRISON 10KW MCR
 COMPARTMENTS: 153 CUBIC FEET



SPARTAN STOCK
 SNYDER, NE
 MODEL: 100' MIDMOUNT PLATFORM (S45MP-100)
 DEALERSHIP: SPARTAN MOTORS, USA, INC.
 SCALE: 1/2\" = 1\" DRAWN BY: KS DATE: 4/19/19
 SIZE: 24\" X 36\" DRAWING NO: S5032 REV: 01
 SHEET: 1 OF 1