

COMPARTMENT DIMENSIONS					
COMPT.	DOOR OPENING	INTERIOR	DIVIDE HEIGHT	UPPER DEPTH	LOWER
L1	34"W x 63"H	36"W x 72"H	N/A	25"	25"
L2	68"W x 31"H	75"W x 38"H	N/A	25"	N/A
L3	44"W x 63"H	44"W x 72"H	N/A	25"	25"
R1	34"W x 63"H	36"W x 72"H	27"	12"	25"
R2	68"W x 31"H	75"W x 38"H	N/A	12"	N/A
R3	44"W x 63"H	44"W x 72"H	27"	12"	25"
T1	36"W x 37"H	46"W x 44"H	N/A	19"	19"

GROUND LADDERS & PIKE POLES			
ITEM	DESCRIPTION	MODEL #	QTY
A	35' 3-SEC EXTENSION	1225-A	1
B	14' ROOF	775-A	1
C	10' FOLDING ATTIC	585-A	1
D	PIKE POLE	-	3

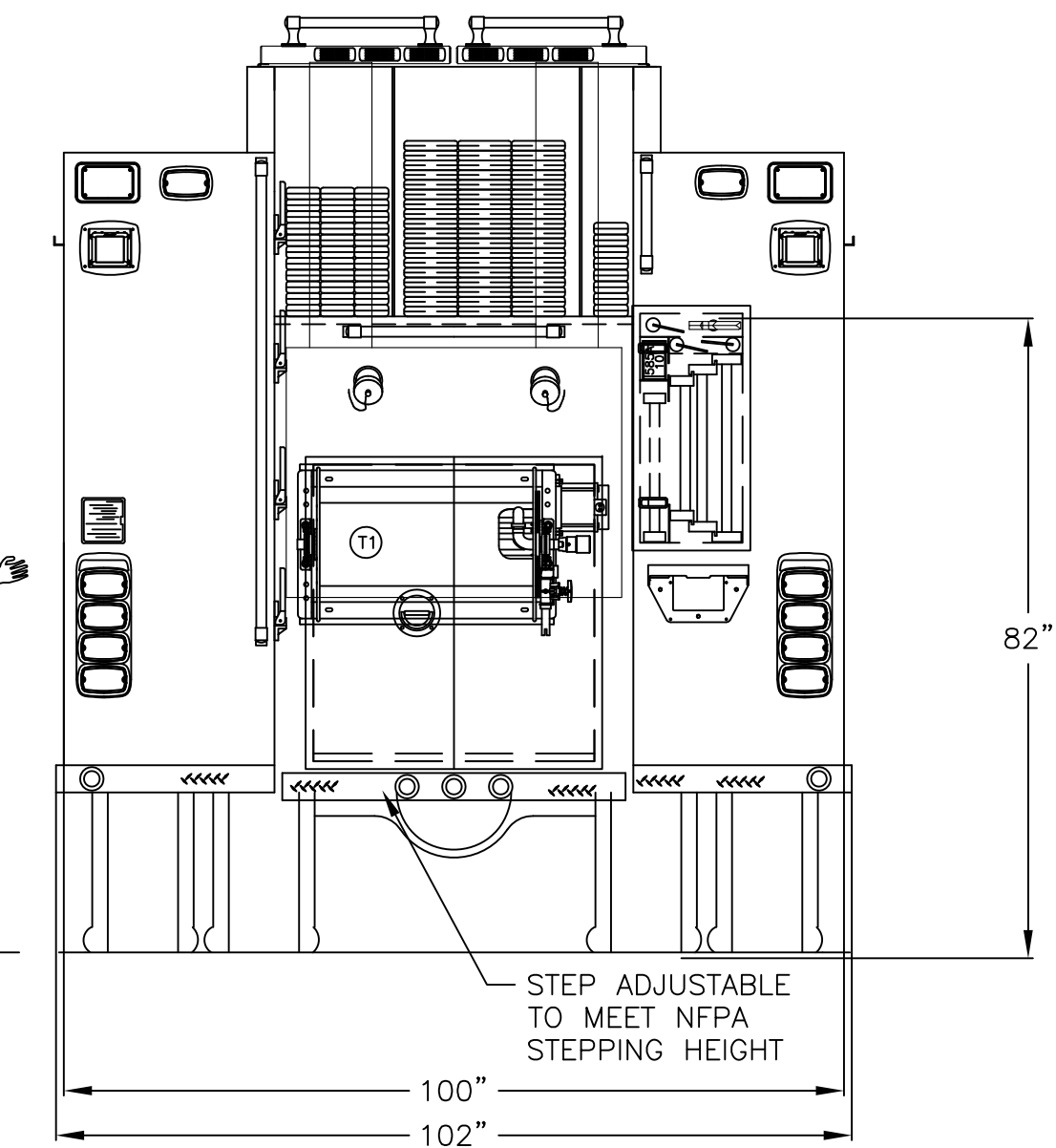
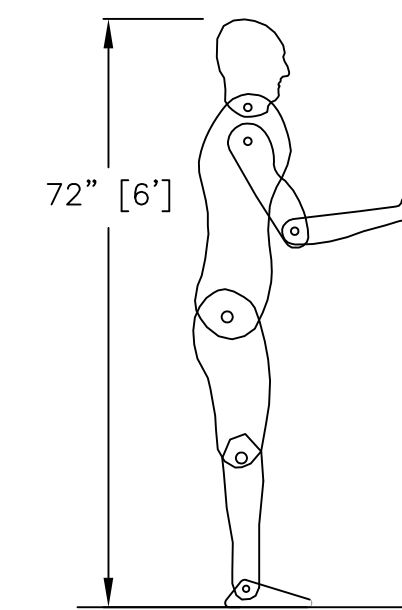
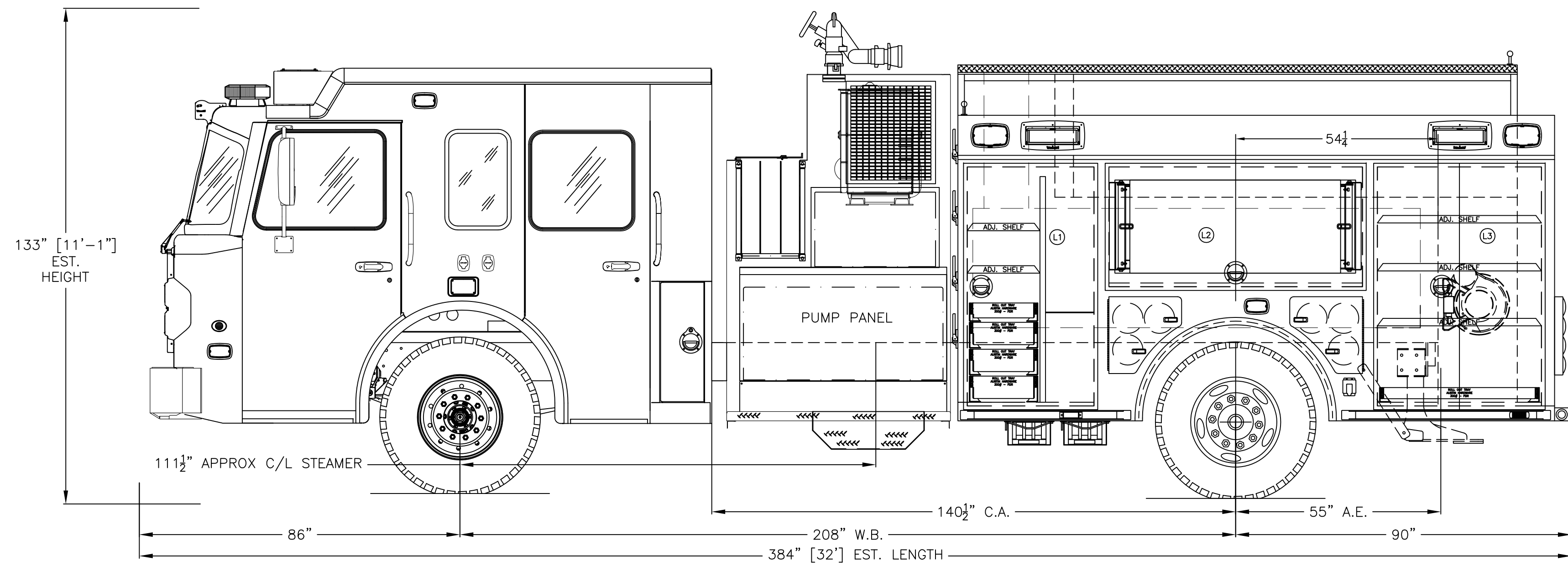

**NOTE:**  
 THIS DRAWING IS THE PROPERTY OF SPARTAN MOTORS USA AND IS TO BE USED ONLY IN REFERENCE TO THE WORK PROPOSED OR CONTRACTED BY SPARTAN MOTORS USA ANY REPRODUCTION IN PART OR IN WHOLE WITHOUT THE WRITTEN PERMISSION OF SPARTAN MOTORS USA IS STRICTLY PROHIBITED.  
 DIMENSIONS SHOWN ARE APPROXIMATE AND ARE SUBJECT TO CHANGE AS MAY BE FOUND NECESSARY DURING CONSTRUCTION. THIS DRAWING MUST BE PLOTTED TO THE PAPER SIZE LISTED IN THE TITLE BLOCK FOR THE LISTED SCALE TO BE VALID.  
 THIS DRAWING IS FOR REFERENCE PURPOSES ONLY. SOME ITEMS MAY OR MAY NOT APPEAR ON THE DRAWING THAT MAY OR MAY NOT BE INCLUDED IN THE SPECIFICATIONS. THE SPECIFICATIONS SHALL BE THE FINAL AUTHORITY TO DETERMINE WHAT IS SUPPLIED ON THE APPARATUS.

REV	INT	DATE	REVISION HISTORY
01	SDS	2/6/19	ORIGINAL LAYOUT FOR ORDER ENTRY
02	SDS	2/20/19	PRECONSTRUCTION CHANGES INCORPORATED

## SHOP ORDER

CHASSIS: SPARTAN GLADIATOR LFD 10" RAISED ROOF  
 ENGINE: CUMMINS X15 600HP WITH ALLISON 4000 EVS  
 PUMP: HALE QMAX 1500 GPM  
 WATER TANK: 500 U.S. GAL  
 FOAM CELL: 30 U.S. GAL  
 BODY MATERIAL: 3/16" ALUMINUM  
 HOSE BED: 99 CUBIC FEET  
 GENERATOR: SG-09  
 COMPARTMENTS: 178 CUBIC FEET



**SMEAL**  
 A SPARTAN MOTORS BRAND  
 610 W 4TH ST  
 SNYDER, NE  
 PHONE: (402) 568-2224  
 WWW.SMEAL.COM

CITY OF KAMPLOOPS  
 KAMPLOOPS, BC  
 MODEL: SIDE MOUNT PUMPER  
 DEALERSHIP: SAFETEK EMERGENCY VEHICLES  
 SCALE: 1/2" = 1'  
 SIZE: 24" X 36"  
 SHEET: 1 OF 1  
 DRAWN BY: S. STUMPE  
 DATE: 2/6/19  
 DRAWING NO: S4974  
 REV: 02