

- 12' 6"
- 12' 0"
- 11' 6"
- 11' 0"
- 10' 6"
- 10' 0"
- 9' 6"
- 9' 0"
- 8' 6"
- 8' 0"
- 7' 6"
- 7' 0"
- 6' 6"
- 6' 0"
- 5' 6"
- 5' 0"
- 4' 6"
- 4' 0"
- 3' 6"
- 3' 0"
- 2' 6"
- 2' 0"
- 1' 6"
- 1' 0"
- 6"

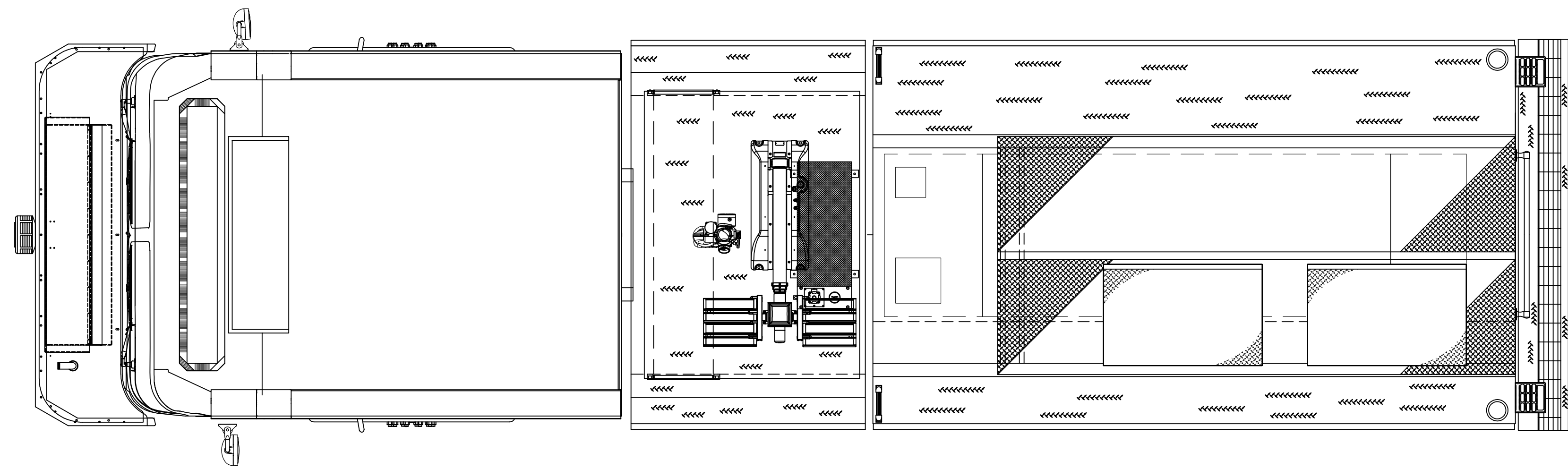

COMPARTMENT DIMENSIONS					
COMPT.	DOOR OPENING	INTERIOR	DIVIDE HEIGHT	USG. DEPTH	LOAD
L1	41"W x 58"H	46"W x 72"H	N/A	26"	25"
L2	59"W x 26"H	69"W x 38"H	N/A	26"	N/A
L3	47"W x 58"H	50"W x 72"H	N/A	26"	26"
R1	41"W x 58"H	46"W x 72"H	27"	15"	26"
R2	59"W x 26"H	69"W x 38"H	N/A	15"	N/A
R3	47"W x 58"H	50"W x 72"H	27"	15"	26"
T1	42"W x 27"H	46"W x 30"H	N/A	25"	25"

GROUND LADDERS & PIKE POLES			
ITEM	DESCRIPTION	MODEL #	QTY
A	24' 2-SEC EXTENSION	900-A	1
B	14' ROOF	775-A	1
C	10' FOLDING ATTIC	585-A	1
D	PIKE POLE	-	3

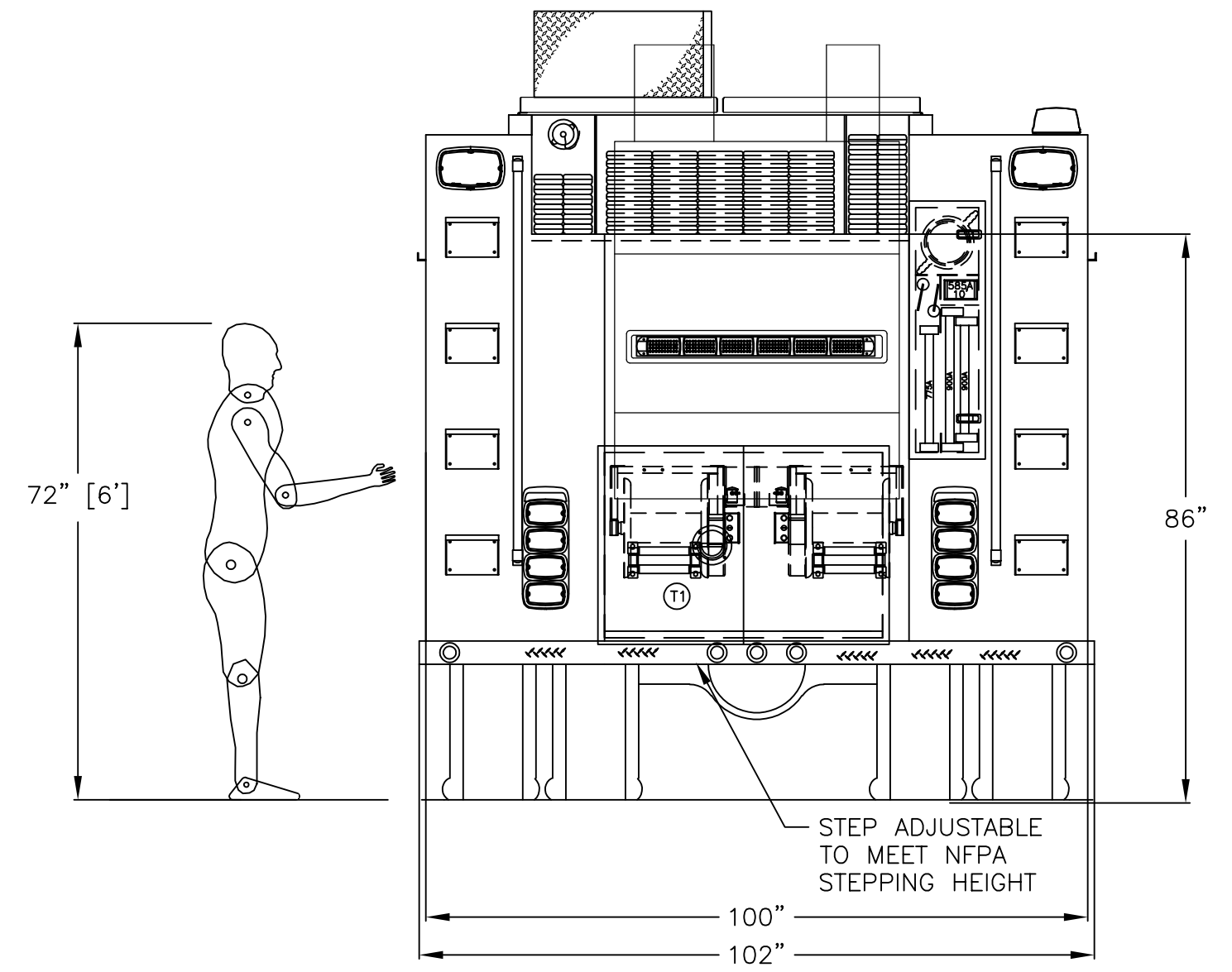
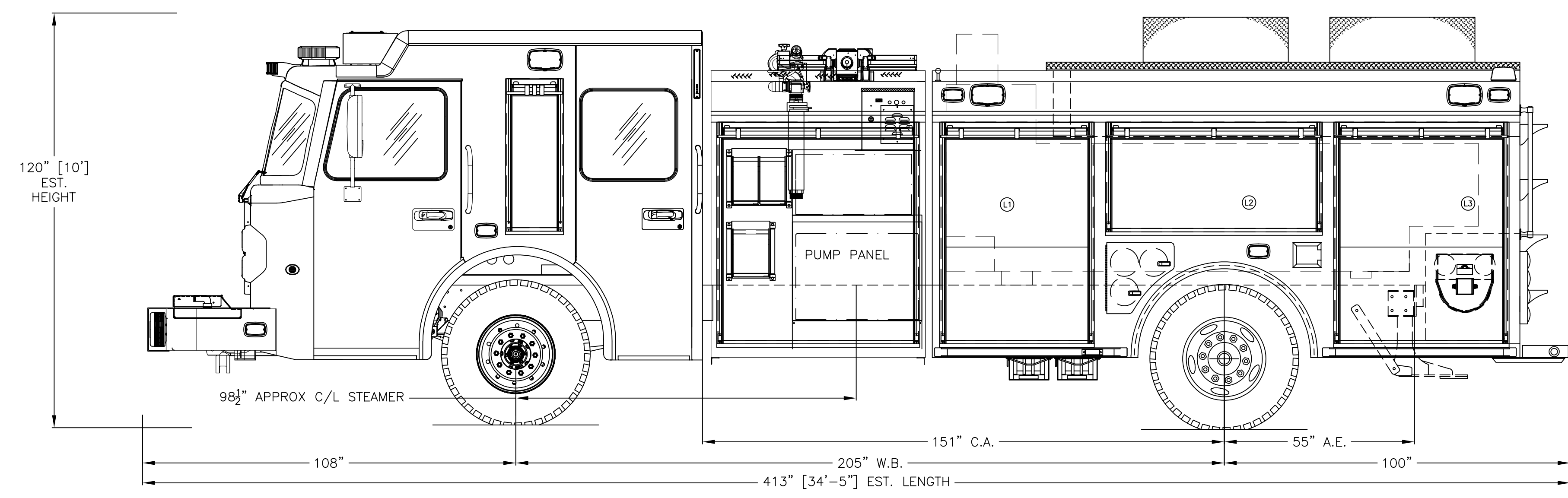

NOTE:
 THIS DRAWING IS THE PROPERTY OF SPARTAN FIRE LLC AND IS TO BE USED ONLY IN REFERENCE TO THE WORK PROPOSED OR CONTRACTED BY SPARTAN FIRE LLC ANY REPRODUCTION IN PART OR IN WHOLE WITHOUT THE WRITTEN PERMISSION OF SPARTAN FIRE LLC IS STRICTLY PROHIBITED.
 DIMENSIONS SHOWN ARE APPROXIMATE AND ARE SUBJECT TO CHANGE AS MAY BE FOUND NECESSARY DURING CONSTRUCTION. THIS DRAWING MUST BE PLOTTED TO THE PAPER SIZE LISTED IN THE TITLE BLOCK FOR THE LISTED SCALE TO BE VALID.
 THIS DRAWING IS FOR REFERENCE PURPOSES ONLY. SOME ITEMS MAY OR MAY NOT APPEAR ON THE DRAWING THAT MAY OR MAY NOT BE INCLUDED IN THE SPECIFICATIONS. THE SPECIFICATIONS SHALL BE THE FINAL AUTHORITY TO DETERMINE WHAT IS SUPPLIED ON THE APPARATUS.

REV.	INT.	DATE	REVISION HISTORY DESCRIPTION
01	Brodd	01/27/21	ORIGINAL LAYOUT

PROPOSAL

CHASSIS: SPARTAN METRO STAR MFD 10" RAISED ROOF
 ENGINE: CUMMINS L9 450HP WITH ALLISON 3000 EVS W/RETARDER
 PUMP: WATEROUS CSUC20 2000 GPM (RATED @ 7000 LPM)
 WATER TANK: 750 IMP. GAL
 FOAM CELL: 20 IMP. GAL
 BODY MATERIAL: 1/8" ALUMINUM
 HOSE BED: 77 CUBIC FEET
 GENERATOR: HARRISON 8KW MCR
 COMPARTMENTS: 205 CUBIC FEET



WHITCHURCH-STOUFFVILLE FIRE & EMGCY
 WHITCHURCH-STOUFFVILLE, ON
 MODEL: ENCLOSED SIDE MOUNT PUMPER
 DEALERSHIP: SAFETEK EMERGENCY VEHICLES
 SCALE: 1/2" = 1' DRAWN BY: D.Brodd DATE: 01/27/21
 SIZE: 24" X 36" DRAWING NO: 21451 REV: 01
 SHEET: 1 OF 1