

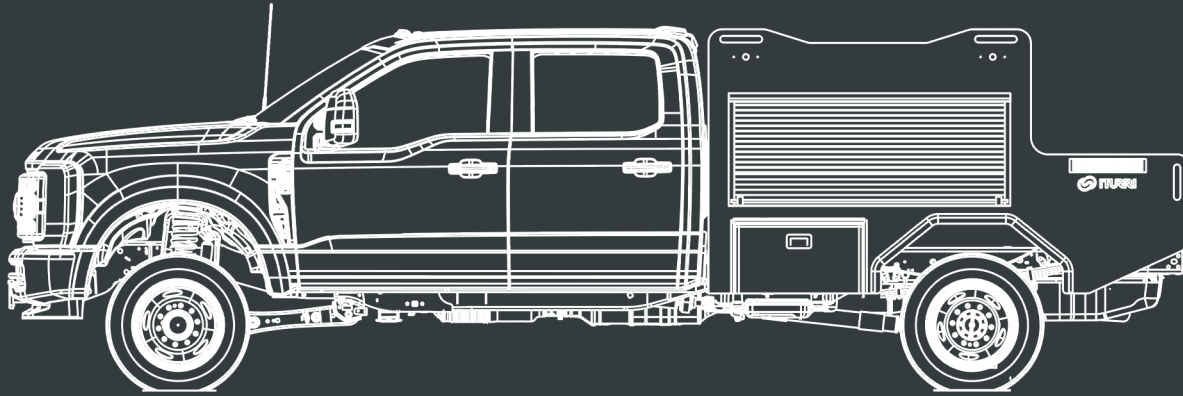

SAFETEK PROFIRE



# WILDLAND 6

The Most Remarkable Type 6 Wildland Engine.



Scan to learn more.

[firetrucks.ca/demo/wildland6](https://firetrucks.ca/demo/wildland6)

SAFETY IS OUR BUSINESS. SERVING THOSE WHO KEEP OUR COMMUNITIES SAFE

Instagram Facebook Twitter YouTube | @SafetekProfire

Visit us at [firetrucks.ca](https://firetrucks.ca)

# WILDLAND 6

## SPECIFICATIONS

### TANK

- 350 IMP Gallon Water Tank
- 12 IMP Gallon Foam Tank
- High-strength polypropylene integrated to the body.

### CHASSIS

- Ford F550 XL Crew Cab, 4x4.
- 179.8" WB, 60.0" CA.
- Engine: 6.7 Power Stroke V8
- Turbo Diesel.
- Transmission: 10-speed TorqShift Automatic.

### PUMP

- Waterax BB-4-21H 4 Stage High Pressure Pump.
- Gasoline Fueled.

### FOAM PROPORTIONING SYSTEM

- Scotty Around-The-Pump (ATP).
- Class A.

### HOSE REEL

- Hannay Reel INC.
- 100ft 1" booster hose.

### INTAKES/DISCHARGES

- High flow TIG welded stainless steel discharge and suction manifolds.
- Rear Discharges:
  - 2 x 1-1/2"
  - 1 x 1" - Hose Reel
- Suction: 1x 2-1/2"
- Tank Fill: 1x 1-1/2"

### LIGHTING

- Whelen Emergency and Scene Lighting Package.

### BODY AND COMPARTMENTS

- Lightweight integrated construction.
- High-strength polypropylene 1 compartment per side.
- Aluminum roll-up doors.

### OPTIONS

- Front Brushguard Front Bumper.
- Front Winch Warn 16T- 12V Electric.
- Super Single 335/80R20 Wheel/Tires.
- Ground Sweeps.
- Cab Controlled Monitor:
  - Requires front bumper option
- Front Discharges:
  - 1 x 2" - Monitor
  - Requires front bumper option

\*Specifications subject to change.



# WILDLAND 6

## DRAWINGS

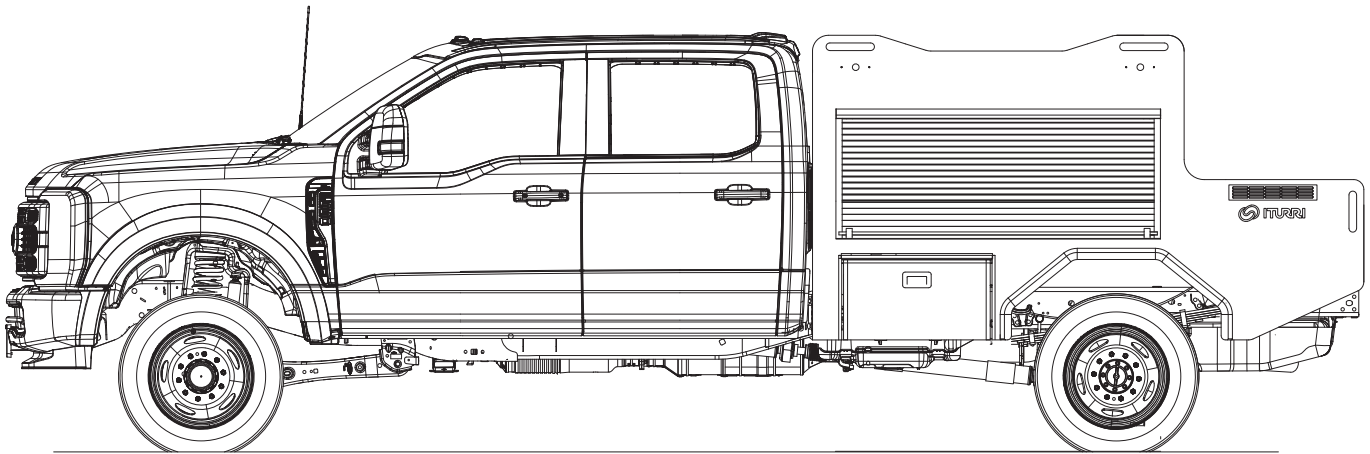
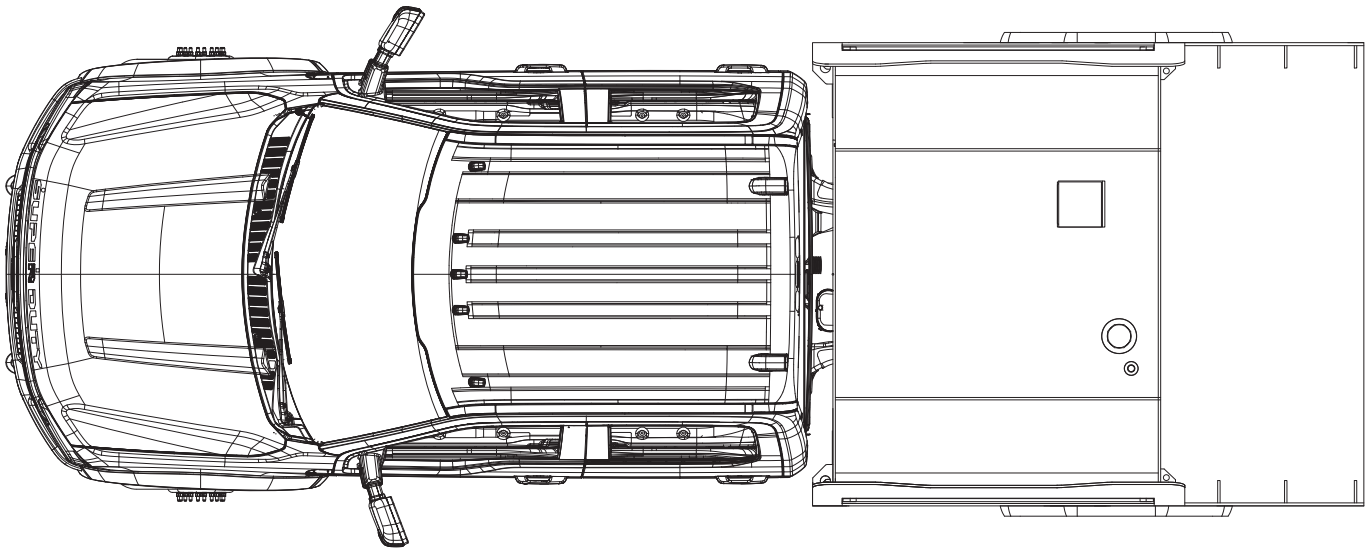

\*Specifications subject to change.