



WILDLAND 3

The Most Remarkable Type 3 Wildland Engine.



firetrucks.ca/wildland3

Scan to learn more.

WILDLAND 3

SPECIFICATIONS

WATER AND FOAM

- 500 IMP gallons water
- 12 IMP gallons foam
- High-strength polypropylene integrated to the body

CHASSIS

- International CV Series 515 Crew Cab, 4x4. 175" WB, 60" CA.
- Engine: International® 6.6 V8 Turbo-charged Diesel. Engine:
 - 350 hp @ 2700 RPM.
 - 700 lb. - ft. torque @1600 RPM.
- Transmission: Allison 2750 EVS.
- GVWR 23,000Lbs.
- Tire Size: 255/70R22.5.
- Spare tire included. Hoist support for spare tire.
- Heavy duty bumper.

PUMP

- Darley HM350 PTO
- Electric Priming System NFPA Rate.
- Pump and Roll Capable.

FOAM PROPORTIONING SYSTEM

- Trident FOAMATE Around-The-Pump System. Class A.

AUXILIARY PUMP

- Darley 1.5 AGE 10YD Diesel engine

MONITOR OPTIONS

- Elkhart Brass 8495
- Akron Forestry 3462
- Cab controlled.
- Located in front bumper.

HOSE REEL

- Electric Hose Reel.
- Hannay Reel
- 100ft 1" booster hose.
Located in rear compartment

BODY AND COMPARTMENTS

- Lightweight integrated construction.
- Compartment Storage: 2 per side, fully customizable. Option: Isolated Chainsaw compartment.
- Aluminum roll-up doors. Enclosed rear mount PTO pump

INTAKES/DISCHARGES

- High flow TIG welded stainless steel discharge and suction manifolds.
- Rear Discharges:
 - ·2 x 1 1/2"*
 - ·1 x 1"*
 - ·1 x 1"* - Hose reels
- Front Discharges:
 - ·1 x 2" - Monitor
 - ·1x 1 1/2"*
 - Suction: 2.1/2"
 - Tank Fill: 1x 2"*
 - Valves: Akron

PRESSURE GOVERNOR:

- FRC - Model: PBA400

LIGHTING

- NFPA Compliant Lighting Package.
- Scene Lighting 2 left, 2 right, 1 rear

ROOF

- Hose storage area that meet the NFPA 1901 requirements. Section 6.7, chapter 6. Initial Attack Apparatus.
- Ladder Duo Safety 912-3 20ft Roof Ladder Rack.

COMPLIANCE

- NFPA 1906 compliant.
- NFPA 1901 initial attack compliant.

COLD WEATHER OPERATION

- Pump compartment heater and heatpan.

*Specifications subject to change.



WILDLAND 3

DRAWINGS

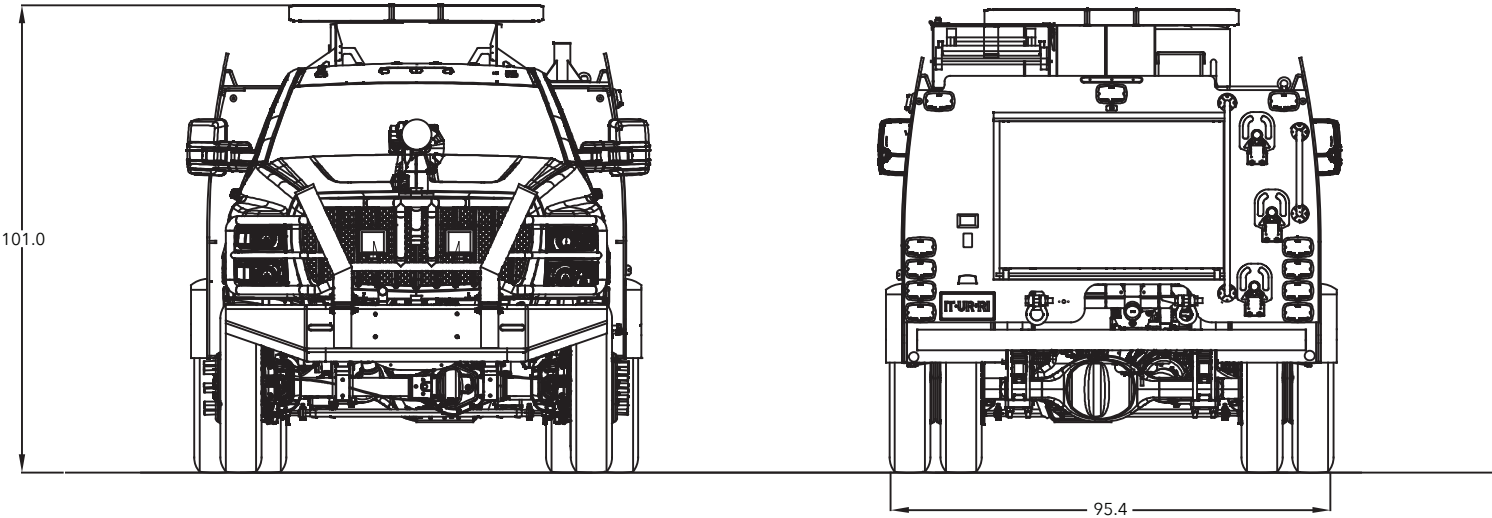
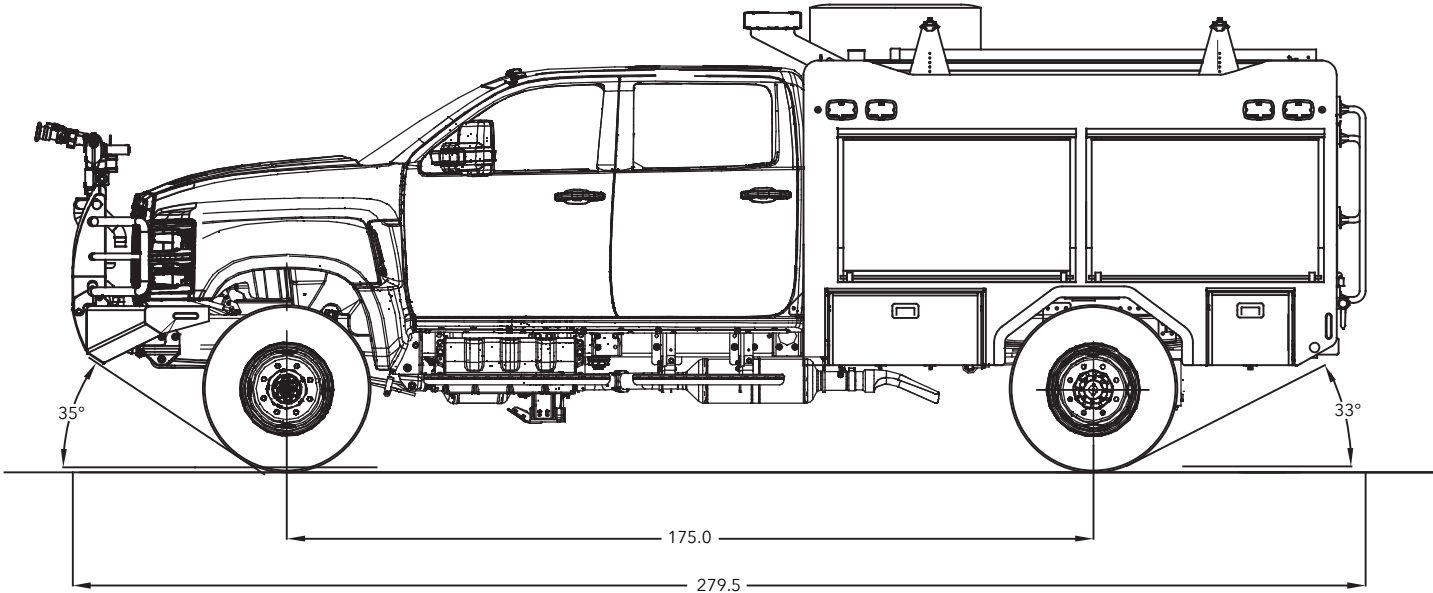

*Specifications subject to change.





* Model Not Exactly As Shown

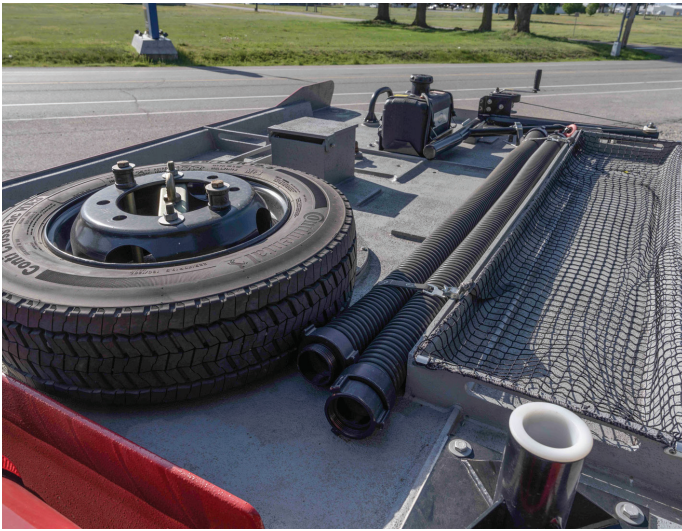
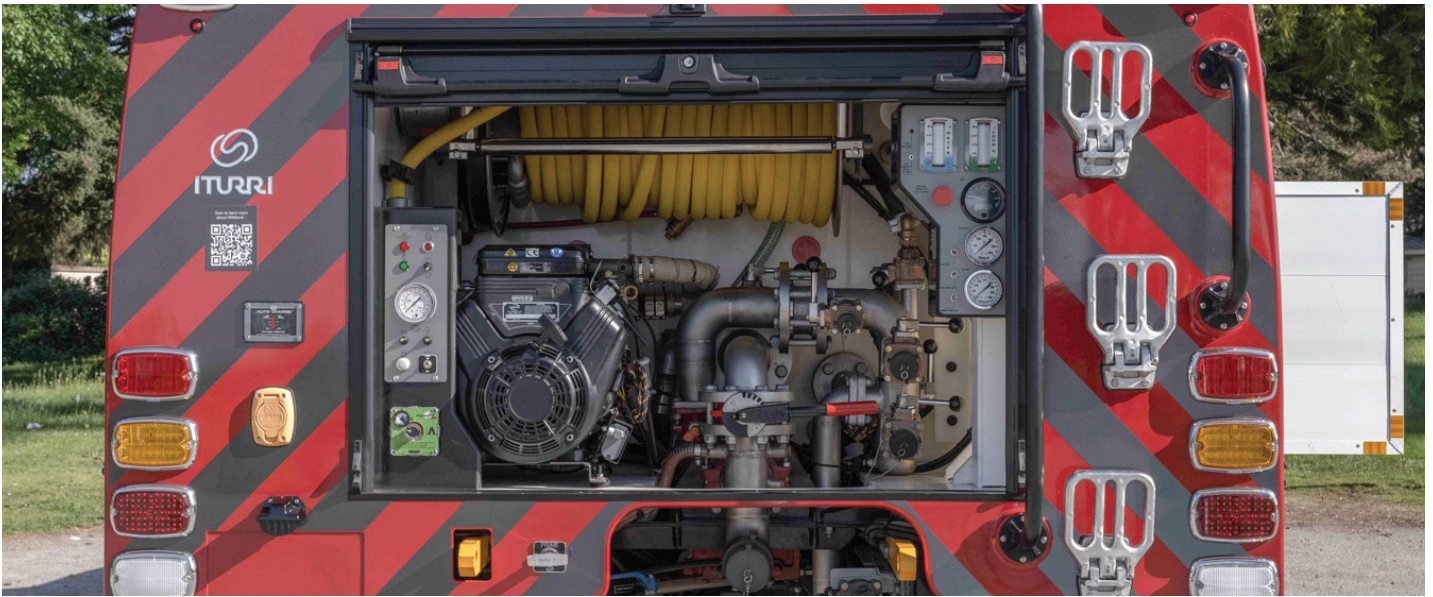

* Model Not Exactly As Shown



WILDLAND 3

Fire Chief Brian Hutchinson



CUSTOMER SPOTLIGHT

Fire Chief Brian Hutchinson of the District of North Vancouver Fire & Rescue Services shares about the impact their order of a Wildland 3 will have on their community.



Scan to view.

