



WILDLAND 5

The Most Remarkable Type 5 Wildland Engine.



firetrucks.ca/demo/wildland5

Scan to learn more.

WILDLAND 5

SPECIFICATIONS

TANK

- 500 IMP gallons water.
- 12 IMP gallons foam.
- High-strength polypropylene integrated to the body.

CHASSIS

- International CV Series 515 Crew Cab, 4x4. 175" WB, 60" CA. Engine: International® 6.6 V8 Turbocharged Diesel. Engine:
 - 350 hp @ 2700 RPM.
 - 700 lb. - ft. torque @1600 RPM.
- Transmission: Allison 2750 EVS. GVWR 23.000Lbs.
- Tire Size: 255/70R22.5
- Spare Tire included.
- Heavy duty bumper

PUMP [OPTIONS]

- Waterax BB-4-21H 4 Stage High Pressure Pump

FOAM PROPORTIONING SYSTEM

- Scotty Around-The-Pump (ATP)
- Class A.

MONITOR OPTIONS

- TFT 2.5" Tornado
- Cab controlled.
- Located in front bumper.

HOSE REEL

- Electric Hose Reel.
- Hannay Reel
- 100ft 1" booster hose. Located in rear compartment

BODY AND COMPARTMENTS

- Lightweight integrated construction.
- Compartment Storage: 2 per side, fully customizable.
- Aluminum roll-up doors. Enclosed rear engine pump

INTAKES/DISCHARGES

- High flow TIG welded stainless steel discharge and suction manifolds.
- Rear Discharges:
 - 2 x 1 1/2"
 - 1 x 1" - Hose reels
- Front Discharges:
 - 1" - Monitor
- Suction: 2.1/2"
- Tank Fill: 1x 1.5"
- Valves: Akron

LIGHTING

- Whelen Emergency and Scene Lighting Package.

ROOF

- Ladder Duo Safety 912-3 20ft Roof Ladder Rack.
- Hoist support for spare tire.

*Specifications subject to change.



WILDLAND 5

DRAWINGS

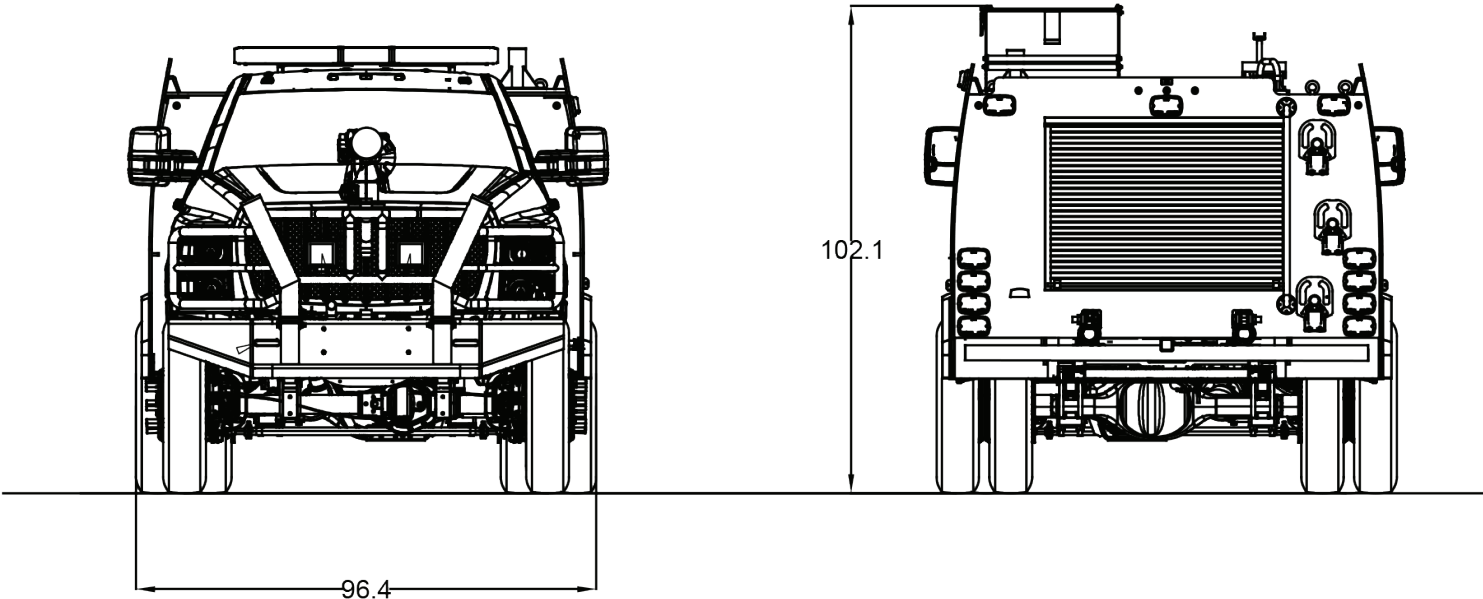
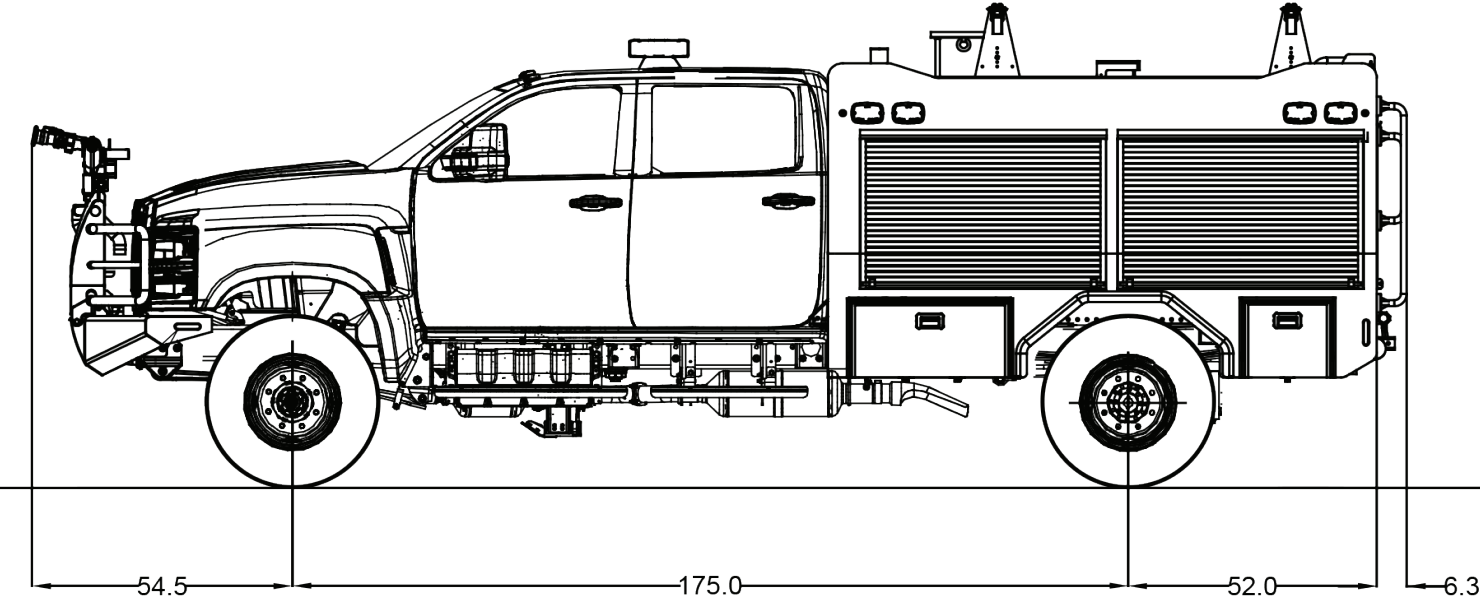

*Specifications subject to change.



* Model Not Exactly As Shown

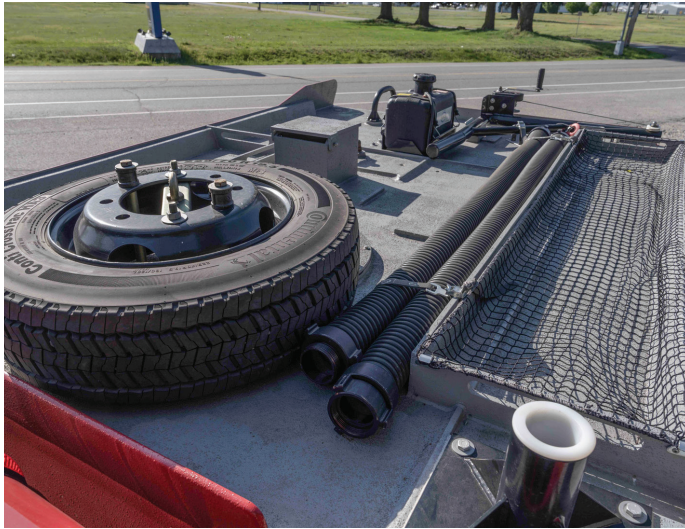

* Model Not Exactly As Shown