

** TIRE SIZE:
335 80/R20

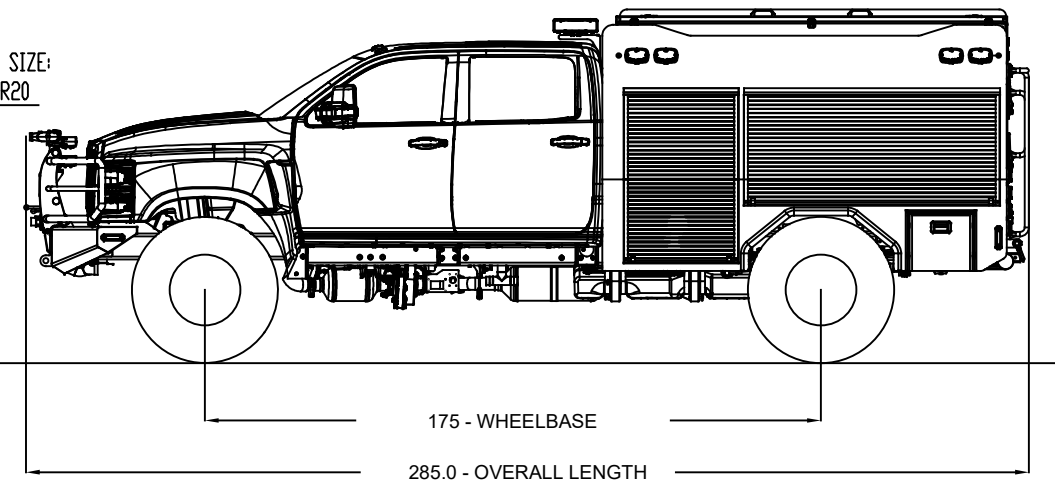

FEATURES:

- INTERNATIONAL CV515 4X4 CHASSIS
- HALE RSD 1250gpm
- DARLEY PUMP 1 1/2AG PUMP & ROLL - OPTIONAL
- TANK CAPACITY: 600gal WATER+ 15gal FOAM
- HANNAY HOSE REEL - 1" X 100ft
- FULLY CUSTOMIZABLE STORAGE COMPARTMENTS
- 2 - 2 1/2" DISCHARGE
- 2 - 1 1/2" PRE-CONNECT DISCHARGE
- 1 - 1 1/2" FRONT DISCHARGE
- 1 - 6" SUCTION INTAKE
- 1 - 2 1/2" TANK FILL
- 1 - 2" FRONT MONITOR - OPTIONAL
- DUAL AND SINGLE TIRE SIZE OPTIONS
- LADDER COMPARTMENT ON THE ROOF - OPTIONAL

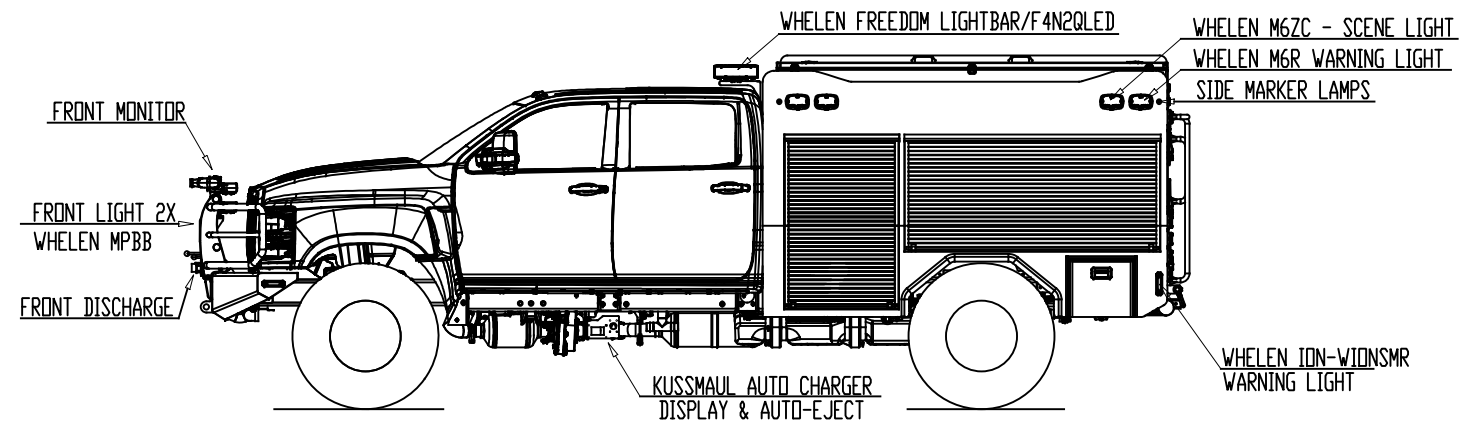
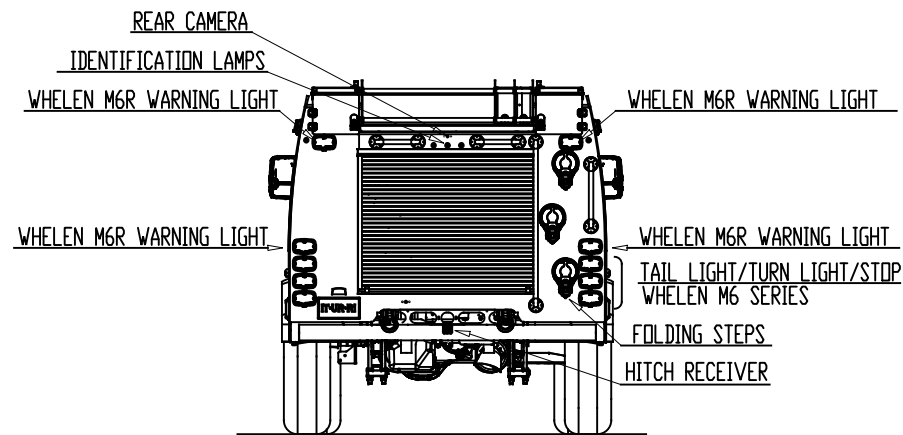
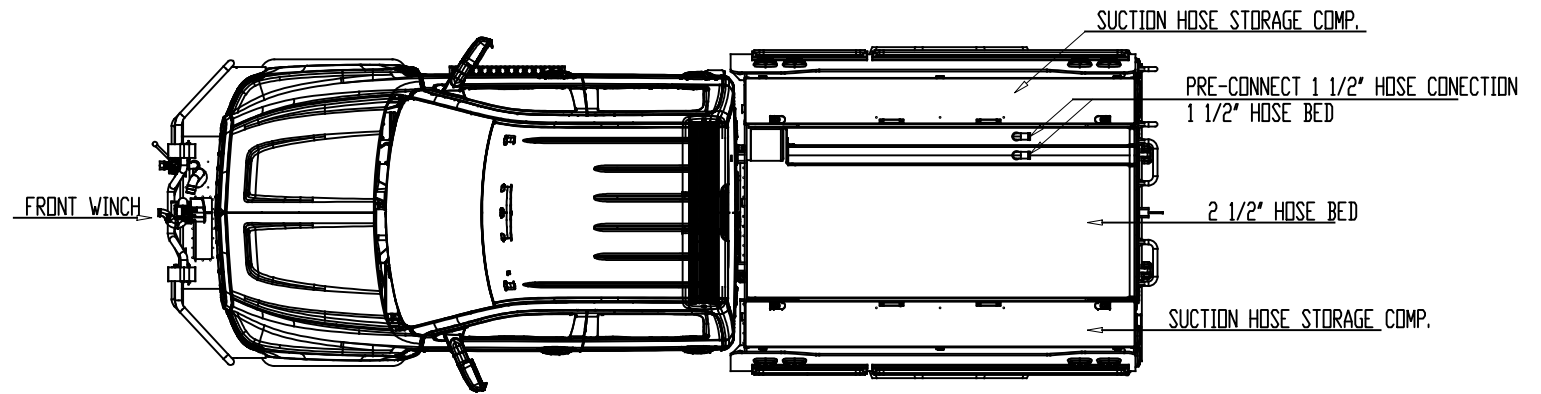

The information contained in this document is property of ITURRI, S.A. Unauthorized total or partial copy to third parties is strictly prohibited.

NOTE:
ALL MEASUREMENTS AND PERFORMANCES ARE CALCULATED ACCORDING TO INFORMATION SUPPLIED BY THE VEHICLE'S MANUFACTURER. ITURRI RESERVES THE RIGHT TO MAKE DESIGN MODIFICATIONS WITHOUT PRIOR NOTICE

Unit: in

	NAME	DATE	PRODUCT NAME: ITURRI WILDLAND - MINIPUMPER	CODE: -
	DESIGNED	MJP	29/09/2023	SHEET: 1 OF 1
	APPROVED	EDL	23/11/2023	
DRAWING: D0239 00 000 00				